

Home Adaptations for Disabled Persons

Fact Sheet No. 9.529

Consumer Series | Housing

by K.R. Tremblay, Jr. and C. Birdsong*

Various estimates place the number of Americans with disabilities at about 54 million people. A precise and reliable overall figure is not available, due to different definitions of disability, sources of data, and survey methods. These make it impossible to aggregate much of the available data.

It is estimated that there are 400,000 Coloradans with physical or mental disability. Even if the numbers are not precise, this is a sizable portion of the population. Many depend on a wheelchair for their mobility.

The information contained in this fact sheet is for people using wheelchairs and their family members and friends. The suggestions are simple, inexpensive and suitable for renters as well as homeowners. The American National Standards Institute (ANSI), a recommended publication, is the basis for the majority of the physical dimensions cited.

For people interested in architecture or design for the disabled and using the ANSI standards, it is helpful to understand the difference between accessibility and adaptability. ANSI A117.1-1986 describes **accessibility** as a site, building, facility or portion thereof that can be approached, entered and used by physically disabled people. **Adaptability** is the flexibility of certain building elements (such as kitchen counters, sinks and grab bars) to be modified to accommodate the needs of people with different types or degrees of disability. The 1990 Americans With Disabilities Act (ADA) uses both terms and is based on the ANSI standard.

Wheelchair Maneuvering Space

The average dimensions of a standard adult manual wheelchair (occupied) are (Figure 1):

- length: 46 to 50 inches including allowance for projection of feet to overhang,
- width: 23 to 32 inches allowing for hands and elbows,
- seat depth: 16 inches,
- seat height: 19-20 inches, and
- arm height: 29-30 inches from floor.

The sports wheelchair, which has cambered wheels, has a lower seat and is wider, but the overhead reach is not as high as the standard model.

The average distance needed for an adult in a wheelchair to make a complete circle is 60 inches of clear floor space. Minimum clear width for a wheelchair is 36 inches for a hall and 32 inches for a door. Minimum clear space for a T-shaped turn of 180 degrees is 36 inches in all directions. The minimum passage width for one wheelchair and one ambulatory person is 48 inches.

The average reaching distance of a seated adult: side reach maximum height overhead is 54 inches and the low side reach is 9 inches above the floor (Figure 2). This does not include reaching over an obstacle such as a counter. The maximum forward reach is 48 inches above the floor, also not over an obstacle.

Ramps

A properly constructed ramp is essential for anyone in a wheelchair to use a building. A ramp can replace stairs or be part of an accessible route to a building's entrance. An accessible route is the shortest possible path from a handicapped parking space to an accessible entrance. There should be at least one accessible route from a public street, sidewalk or parking space to an accessible entrance, as well as routes from adjacent buildings.

Ramps are required any time there is an elevation in the grade of the land that wheelchairs must maneuver. The maximum slope of any ramp is 1:12. This ratio means

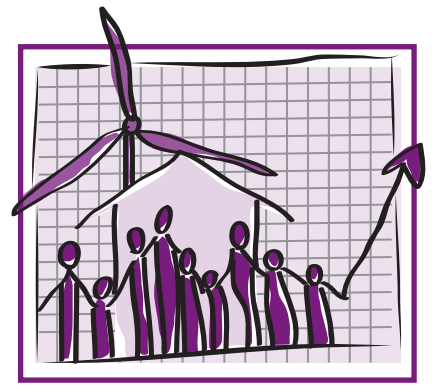

Quick Facts

- Many Coloradans with disabilities depend on a wheelchair.
- Accessibility describes a site, building, facility or portion thereof that can be approached, entered and used by physically disabled people.
- Adaptability describes the flexibility of certain building elements to be modified to accommodate the needs of people with disabilities.
- A properly constructed ramp is essential for anyone in a wheelchair to use a building.
- When designed correctly, an accessible kitchen can be easily used by everyone in the household.

*K. Tremblay, Colorado State University Extension housing specialist and professor; and C. Birdsong, professor, design and merchandising. 12/2007



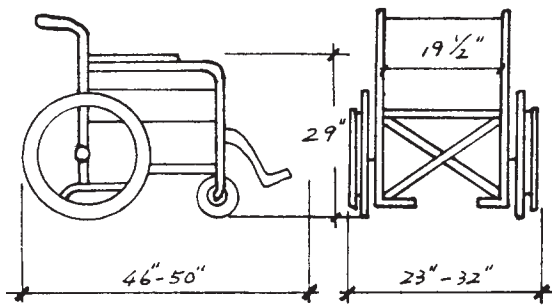

Figure 1.

handrails should extend 12 inches beyond the top and bottom of the ramp and should have a clear space of 1 1/2 inches between the handrail and the wall. There should be 30 to 34 inches from the floor of the ramp to the top of the handrail. Children require a lower handrail.

The two most common materials for ramp construction are wood and concrete. Wood is easier and faster to construct, relatively inexpensive, and can last for years.

All ramps and landings need a nonskid surface and should be designed so water will not accumulate. The surface of concrete ramps must be textured. Two ways to make wooden ramps nonskid are pebble-grained paper or sand mixed with paint. In Colorado, keep snow-melt materials handy to use on ramps and landings during inclement weather.

Every ramp must be custom built to conform to the specific site. Chapter 3 of *How To Create Interiors for the Disabled* provides detailed directions on ramp building.

A clearance of 18 inches on the latch side of the door allows for an easier and safer opening. A shelf, attached to the exterior or interior wall of the structure and adjacent to the door, permits a wheelchair user to put packages down while unlocking and opening the door.

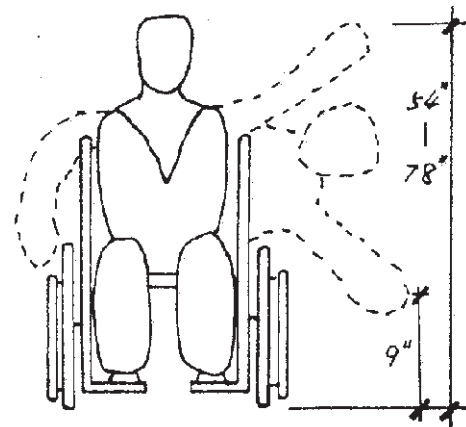

Figure 2.

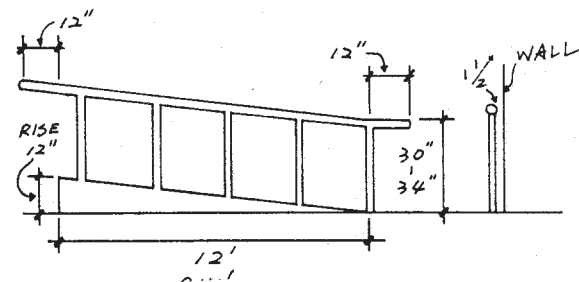

Figure 3.

that for every inch of height in grade change, 12 inches of ramp length is required (Figure 3). The ramp length (or run) should not exceed 30 feet without landings, nor should the ramp rise more than 30 inches. The minimum width of a ramp is 36 inches. Because of inclement weather (snow, ice, wind, etc.), some states have developed a second standard for exterior ramps and walkways. One to 12 remains the standard for interior ramps, and 1:20 is the ratio for exterior ramps.

Landings are required at both the top and bottom of a ramp and should be at least as wide as the ramp (36 inches). Landings should have at least 60 inches of clear space at both the top and bottom.

If a ramp longer than 6 feet will also be used by ambulatory people, a handrail is needed on both sides of the ramp. The

than approaching it parallel and twisting sideways in the wheelchair.

If sink cabinet doors are removed, insulate the hot water pipes to prevent leg burns. A 36 inch spray hose allows for rinsing dishes and filling pans.

A functional food preparation area is essential. This can be achieved by removing additional cabinet doors and other parts of the base cabinets, allowing a front approach to a counter and a work area in front. A pull-out cutting board also is very useful. Cut a hole in the board to hold a mixing bowl. A small dining or breakfast table can serve as a work center. If the kitchen is small, a fold-down table hinged to the wall may provide additional work space.

If you own or are buying a home, consider having a section of the base cabinets made adaptable. Make a minimum 30-inch section of counter mounted on heavy duty shelf brackets adjustable for alternative heights. This section is commonly used as the mixing center. Standard counter height increments are 28 inches, 32 inches and 36 inches (36 is standard). The toe space is 10 inches high and 8 inches deep under the cabinet for clearance of wheelchair footrests.

Other recommendations for base cabinets include:

- U-shaped handles for easy use to avoid grasping a knob;
- installing lazy-susans, pull-out trays or storage shelves and pot racks;
- holders for various food wraps attached to the inside of cabinet doors;
- 2 feet of heat-resistant countertop next to the range allowing wheelchair users to slide hot utensils without the danger of trying to lift them;
- using small electrical appliances, which often are easier to handle; and,
- if possible, the installation of a double sink with a shallow (5 to 6 inch) side

Kitchens

There is more information available on modifying a kitchen than any other part of a home. When designed correctly, an accessible kitchen can be used easily by everyone in the household. The information here is general in nature. For more specific information, refer to the sources listed in the references.

Cabinets and Countertops

The recommended minimum clearance between opposing cabinet fronts, countertop edges or walls is 40 inches except for a U-shaped kitchen, which is 60 inches.

If the doors of the base cabinets can be removed and the base of the cabinet can be cut out in front of the sink, a person in a wheelchair can roll up to the sink rather

Checklist of minimum features for the disabled homebuyer

Entrance: level with exterior door or a ramp with an 8.33 percent grade

Doorway width throughout house: 32 inches interior and 36 inches exterior

Hallway width: 42 inches

Bathroom: 4 feet by 4 feet clear floor space

Web sites for adults with disabilities:

Access Board: www.access-board.gov

Access-By-Design: www.access-by-design.com

American Society of Interior Designers: www.asid.org

Assistive Technology Partners, University of Colorado Health Sciences Center: www.uchsc.edu/atp

Center for Universal Design: www.design.ncsu.edu/cud

Easter Seals Colorado: www.eastersealsco.org

disABILITY Information and Resources: www.makoa.org

National Resource Center on Supportive Housing and Home Modification: www.usc.edu/dept/gero/nrcshhm

International Interior Design Association: www.iida.org

Rocky Mountain Disability and Business Technical Assistance Center: www.ada-infonet.org

Web sites for parents of children with disabilities:

Abledata: www.abledata.com

Disability Resources: www.disabilityresources.org

Kidability: www.kidability.com

Resource Foundation for Children with Challenges: www.specialchild.com

or a cushioned rack in one side that can be used to raise the bottom of one side of the sink. The drain of the sink should be in the back for easier reach and maximum leg space around the disposal.

Lower the bottom shelf of the wall cabinets to a maximum of 48 inches above the floor. If renting, consider adding a shelf under the wall cabinet. A variety of types and sizes are available. Under-the-cabinet small appliances are becoming popular.

Before purchasing one, make sure that the wheelchair user can comfortably reach and use it. The book *Adaptable Housing* presents a variety of recommendations.

Storing Food and Utensils

Another aspect of kitchen design that can help or hinder wheelchair users is the placement of food and dishes. Be inventive and try putting items in different places.

Utensils and appliances should be close to the appropriate work areas, even if it means duplicating some items. Hang long barbecue tongs in various locations throughout the house to retrieve things that fall or are too high to reach.

Keep heavy pots, pans, dishes and mixing bowls on bottom shelves, along with canned foods. Pull-out shelves are easy to install and can provide more bottom shelf space. They can be taken with you if you move. Top shelves can hold boxes, glasses and small items, as well as items not used on a regular basis. If the top shelf is made of clear plastic, a person in a wheelchair can see the contents.

Install shelves in a broom closet to convert it into a pantry. Pegboard, attached to the wall and equipped with hooks, is an excellent way to store pots, pans and utensils or anything else used often. An extension gripper permits a seated person to use high shelves that would otherwise be out of reach. Unbreakable, plastic containers and stainless steel bowls also are helpful.

A rolling cart or cutting-block table with wheels can take food, dishes and small appliances to and from the table (particularly if the table is in another room) or used for a work center. A lazy-susan on a shelf in the refrigerator makes it easier to retrieve food from the back. To help see food that is cooking, attach a removable mirror at an angle to the wall behind the cooktop. It is easier to see cooking food from a wheelchair if clear glass cookware is used.

Bathrooms

Bathrooms are a necessity of life – but something most people take for granted. Wheelchair users cannot. Both residential bathrooms and commercial restrooms have two problems in common: narrow doors and no grab bars. If the home is fairly new or the community has accessible housing standards, the walls in the tub area and the walls behind and next to the toilet should have extra blocking. Blocking is a structural

reinforcement within a wall that allows a grab bar to be attached securely. Studs can be used too, but may not be located in the most desirable location.

If the sink is free-standing, install extra support under the front edge of the sink or add an “L” bracket. Disabled people tend to lean heavily on the sink. Countertop sinks are safer for support and access. The doors on under-sink cabinets can be removed much the same as in the kitchen. Again, remember to insulate hot water pipes.

Grab Bars

The purpose of a grab bar is to help support a person. It must be able to support a person's weight until help arrives or the person can right him/herself. A grab bar is both pulled and pushed against. It must withstand at least 250 pounds of pressure.

The standard size for a grab bar is 1 1/4 to 1 1/2 inches in diameter. It should be 1 1/2 inches away from the wall. A sturdy towel rod can be used if it is screwed into a stud or blocking. Make sure it does not rotate in its fittings. With some new construction, blocking is placed in the walls such that grab bars can be installed easily. If there is no blocking in the walls, it can be added. The recommended type is 3/4 inch plywood, 6 to 12 inches wide, toe-nailed (at an angle) into the studs; or a 4 by 8-inch block toe-nailed into the studs.

Heavy-duty towel racks or grab bars can be used if they are anchored securely to the wall. Grab bars come in metal or plastic and in many sizes and colors. Colors are easier to see in an emergency. Medical supply stores, plumbing fixture shops and hardware stores have towel racks and/or grab bars. Grab bars with a slight texture are easier to grip.

Bathtubs

In the bathtub area, the blocking should be the full length of the tub. This allows grab bars to be installed anywhere in the area or in more than one place. The end of the tub (opposite the drain) also needs blocking. This should be the tub width.

If the person can use a tub without assistance, a bath mat is a good way to prevent slipping. There also are a variety of inside-the-tub chairs and benches that can be purchased from medical supply stores. A hand-held shower attachment mounted on the wall will allow either a standing or seated person to easily use the shower. Make sure it has a 6-foot hose and

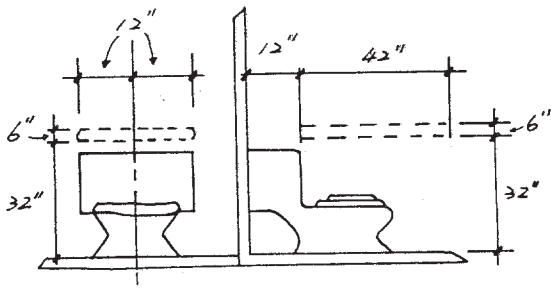

Figure 4.

controls in the handle. The doorway of the bathroom should have a flush sill with a clear opening of 32 inches. If the doorway can be made wide enough by removing the door itself, then a curtain can be hung for privacy. A folding door is another alternative. If the house or apartment has a shower door, replace the door and the metal track with a curtain. It is difficult to transfer over a shower track.

Toilets

At the toilet, the blocked areas should be behind the toilet and on at least one side. If there is no wall next to the toilet, an L-shaped grab bar can be installed by attaching the front end to the floor and the back to the wall behind the toilet. Never install grab bars at an angle (Figure 4).

Since the toilet is often too low for a seated person, the purchase of an elevated toilet seat may be necessary. Portable and permanent toilet seat attachments are available. Some have adjustable seat heights. There also are seats with arms and guard rails. Leave an access space between the toilet seat and the toilet for personal hygiene.

Mirrors and Storage

Another problem area may be small mirrors or high medicine cabinets. A shelf in the base cabinets or items placed on the counter can make up for not being able to reach the medicine cabinet. The mirror on the medicine cabinet can be taken off and lowered, or a wall mirror can be used. If it cannot be lowered, it can be installed at an angle. For extra storage, add narrow shelves where space permits, and hang coated wire racks and/or baskets nearby.

General Information

At least one clear path of travel, without stairs, is required from the front door to at least the following areas: kitchen, dining area, bedroom, bathroom, living room and storage areas. A wheelchair user should have access to at least one bedroom and a full bathroom. Also, provide an alternate exit in case of fire.

Maneuverability within individual rooms is essential for comfort and freedom. You do not need to place all the furniture against the walls. However, make sure there are at least 32 inch aisles for access to television, stereo, telephone, windows, books and hobby supplies. Make sure that supplies and controls for the television and windows are below 48 inches in height. In a small home, you may need to omit some furnishings to prevent congestion.

The wheelchair user generally finds that transferring to a bed, couch or chair is easier and safer if they are the same height as the wheelchair seat. If new furniture cannot be purchased at compatible heights, blocks of wood placed under the legs of furniture can raise existing objects to the desired heights.

Table heights may be too low. It is important that a person's knees and thighs fit comfortably under a dining or work table. The easiest and least expensive table to make is with two sawhorse supports and an old door placed on top. An adjustable height table is more expensive, but it can be lowered for tasks like kneading dough or raised for tasks requiring close work or reading.

Rugs and area carpets can cause extreme hardship for a wheelchair user. Shag rugs show wheel tracks. Chair tires sink into rugs with thick padding, making pushing and turning the chair difficult. Velvet carpets with nap can force the wheelchair in the wrong direction. Avoid scatter or area rugs — they become tangled in the smaller front chair wheels. Low, level, loop pile carpeting with little or no padding is best. In bedrooms, no carpeting is preferred because of frequent turning.

Universal design

More inclusive and broader than the requirements specified in laws and codes, the concept of universal design maximizes the usability of products and environments by all users. The Center for Universal Design defines universal design as an approach to design that accommodates people of all ages, sizes and abilities. There are seven universal design principles that can be applied to accessible housing:

1. **Equitable use** – the design is useful and marketable to people with diverse abilities.
2. **Flexibility in use** – the design accommodates a wide range of individual preferences and abilities.
3. **Simple and intuitive use** – use of the design is easy to understand regardless of the user's experience, knowledge or concentration level.
4. **Perceptible information** – the design communicates necessary information to the user regardless of ambient conditions or the user's sensory abilities.
5. **Tolerance of error** – the design minimizes hazards and adverse consequences of accidental or unintended actions.
6. **Low physical effort** – the design can be used efficiently and comfortably with a minimum of fatigue.
7. **Size and space for approach and use** – appropriate size and space are provided for approach, reach and manipulation regardless of the user's body size, posture or mobility.

Light switches, thermostats, drapery pulls, towel racks and fire alarms (human activated warning systems) have an ideal height of 3 to 4 feet above the floor. They should be no lower than 15 inches above the floor. For people with coordination limits, replace toggle light switches with pressure sensitive switch plates. Also, window locking devices that are reachable and easily managed offer a sense of security.

Most clothes rods in closets are too high to be reached easily by anyone in a seated position. Lower the bar to a maximum height of 54 inches or install an adjustable bar. Many prefabricated closet accessories can be combined in various configurations to meet storage needs. They can be easily dismantled and taken along if you move.

References

- American National Standards Institute. (1986). *American national standard specifications for making buildings and facilities accessible and usable by physically handicapped people*. New York: ANSI.
- Barrier Free Environments. (1989). *Adaptable housing* (HUD-1124-PDR1). Washington: U.S. Department of Housing and Urban Development.
- Brummett, W. (1997). *The essence of home*. New York: Van Nostrand Reinhold.
- Cary, J.R. (1978). *How to create interiors for the disabled*. New York: Pantheon Books.
- Covington, G.A., and Hannah, B. (1997). *Access by design*. New York: Van Nostrand Reinhold.
- Jordan, W.A., *Universal design for the home*. Beverly, MA: Quarry.
- Leibrock, C., and Terry, J.E. (1999). *Beautiful universal design*. New York: John Wiley and Sons.
- Leibrock, C. (2000). *Design details for health*. New York: John Wiley and Sons.
- Lidwell, W., Holden, K., and Butler, J., (2003). *Universal principles of design*. Gloucester, MA: Rockport.
- Lusher, R.H., and Mace, R.I. (1989). Design for physical and mental disabilities. In J.A. Wilkes and R.T. Packard (Eds.), *Encyclopedia of architecture* (pp. 748-763). New York: John Wiley and Sons.
- Raschko, B.B. (1982). *Housing interiors for the disabled and elderly*. New York: Van Nostrand Reinhold.
- Tilley, A., and Henry Dryfuss Associates. (2001). *The measure of man and woman*. New York: John Wiley and Sons.
- U.S. Architectural and Transportation Barriers Compliance Board. (1992). *Americans with disabilities act*. Washington: ATBCB.
- Whirlpool Corporation. (1994). *Designs for independent living*. Benton Harbor, MI: Whirlpool Corporation, Appliance Information Service.
- Wilkoff, W.L., and Abed, L.W. (1994). *Practicing universal design*. New York: Van Nostrand Reinhold.